

# COLLOIDS

## Examples of colloidal systems from daily life



Foams



Milk



Fog, smoke



Detergents

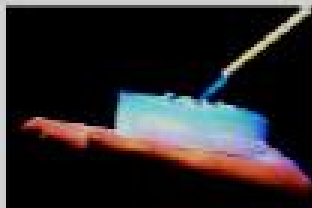

Aerogel



Blood



Paints



Cosmetics

# Colloidal Dispersions

• Dispersed systems consist of :

a) particulate matter (dispersed phase).

b) dispersion medium (continuous medium).

• Classification of dispersed systems (according to particle size):

<u>MOLECULAR DISPERSION</u>	<u>COLLOIDAL DISPERSION</u>	<u>COARSE DISPERSION</u>
- Less than 1 $\mu\text{m}$ - Particles undergo rapid diffusion e.g. $\text{O}_2$ & glucose	- 1 $\mu\text{m}$ to 500 $\mu\text{m}$ - Very slow diffusion e.g. colloidal silver sol.	- Greater than 500 $\mu\text{m}$ - Don't diffuse e.g. suspension & emulsion

# Colloidal Dispersions

<b><u>MOLECULAR DISPERSION</u></b>	<b><u>COLLOIDAL DISPERSION</u></b>	<b><u>COARSE DISPERSION</u></b>
<ul style="list-style-type: none"><li>-Particles invisible in electron microscope.</li><li>-Pass through semipermeable membranes and filter paper.</li></ul>	<ul style="list-style-type: none"><li>-Particles resolved by electron microscope.</li><li>- Pass through filter paper but not pass through semipermeable membrane.</li></ul>	<ul style="list-style-type: none"><li>-Particles are visible under ordinary microscope.</li><li>- Do not pass through filter paper or semipermeable membrane.</li></ul>

# Types of colloidal systems:

---

○ According to the **interaction** between particles of dispersed phase & those of dispersion medium:

**1) Lyophilic (solvent loving).**

**2) Lyophobic (solvent hating).**

**3) Association (amphiphilic).**

---

- **N.B.**

- **SOL. = COLLOIDAL SOLUTION.**

---

- **DISPERSION MEDIUM = SOLVENT.**

- **DISPERSED PHASE = MATERIAL = COLLOIDAL PARTICLES.**

# 1) Lyophilic colloids

- Colloidal particles interact to an appreciable extent with the molecules of the dispersion medium (*solvent loving*).
- **Obtained simply** by dissolving the material in the solvent ( due to the high affinity).

## Types of lyophilic colloids;

(According to type of solvent)



### •Hydrophilic colloids;

•Solvent: water.

•Example: acacia, insulin.... in water.

### •Lipophilic colloids;

•Solvent: non- aqueous, organic solvent.

•Example: rubber & polystyrene.

**SO**; *material that form lyophilic colloid in a certain solvent may not do so in another solvent*, e.g.; acacia + water  $\longrightarrow$  lyophilic colloid (hydrophilic type).

acacia + benzene  $\longrightarrow$  NO lyophilic colloid formed.

# 1) Lyophilic colloids

---

- the dispersed phase does not precipitate easily
  - the sols are quite stable as the solute particle surrounded by two stability factors:
    - a- negative or positive charge
    - b- layer of solvent
  - If the dispersion medium is separated from the dispersed phase, the sol can be reconstituted by simply remixing with the dispersion medium. Hence, these sols are called **reversible sols**
-

## 2) Lyophobic colloids

- Colloidal particles have very little or no attraction for the dispersion medium (*solvent hating*).

---
- Colloidal particles: inorganic particles (e.g. gold, silver, sulfur....)  
Dispersion medium: water.
  - These colloids are easily precipitated on the addition of small amounts of electrolytes, by heating or by shaking
  - Less stable as the particles surrounded only with a layer of positive or negative charge
  - Once precipitated, it is not easy to reconstitute the sol by simple mixing with the dispersion medium. Hence, these sols are called **irreversible sols**.
- Not obtained simply i.e need special method for preparation

---

## 2) Lyophobic colloids

---

### ○ Methods to prepare lyophobic colloids:

#### A) Dispersion methods:

○ coarse particles are reduced in size by;

1) Ultrasonic generator

2) Electric arc.

3) Colloid mill.

---

## 1) Ultrasonic generator:

- Dispersion achieved by high intensity UG at frequency more than 20,000 cycles/second
- 

## 2) Electric arc:

- Involves production of an electric arc within the liquid and dispersion achieved by intense heat generated by the arc so some metal of the electrodes dispersed as vapor then condense to colloidal particles.

## 3) Colloidal mill:

- Material sheared between 2 rapidly rotating close plates.
  - Low efficiency & reduce the size of small proportion of particles only.
-

## 2) Electric arc:

---

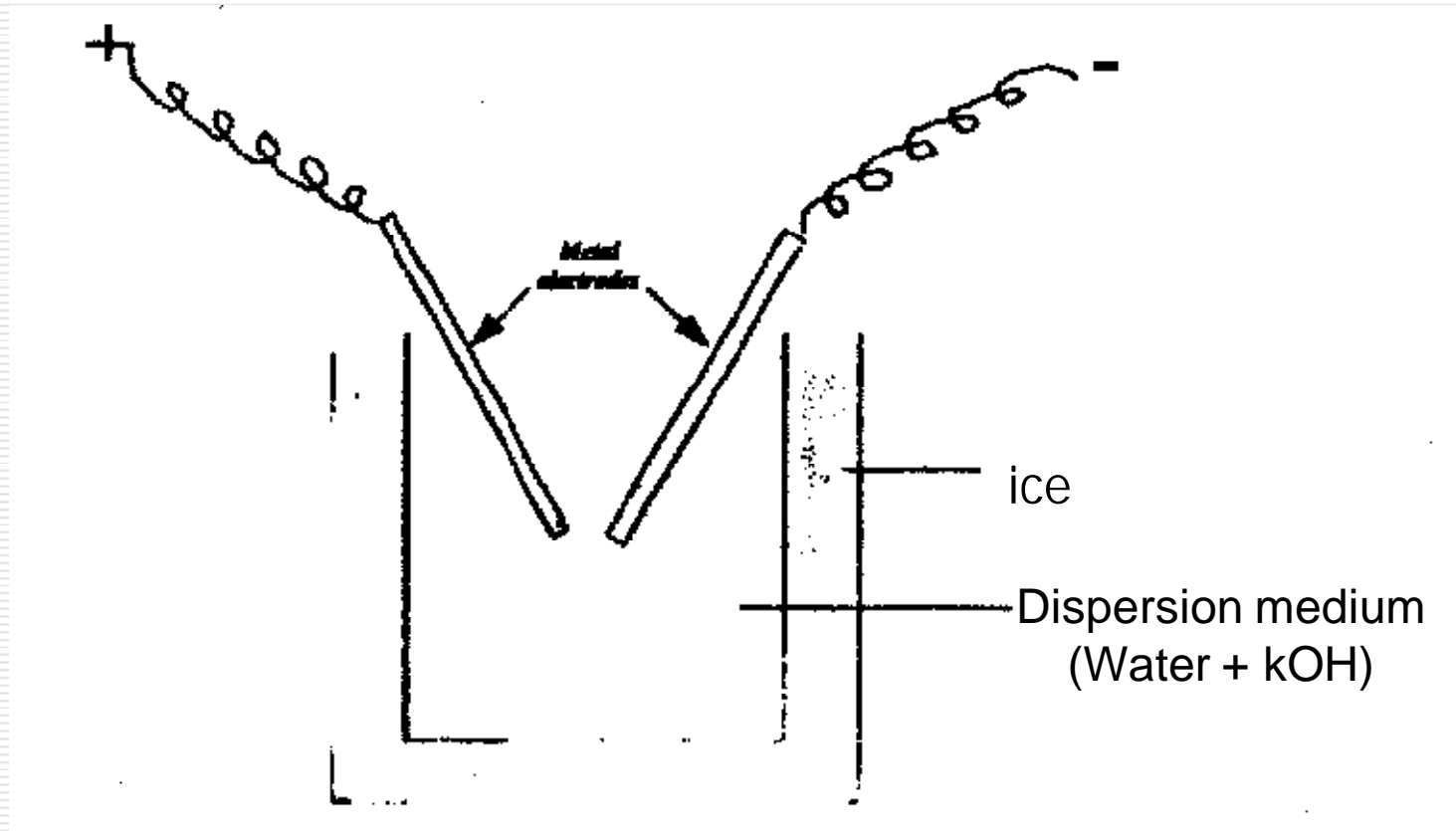

## • B) Condensation methods:

• materials of sub colloidal dimensions are caused to aggregate into particles with colloidal size range by;

1) Change in solvent.

2) Chemical reaction.

### 1) Change in solvent:

- Change in solvent  $\longrightarrow$  Super saturation  $\longrightarrow$  Formation & growth of nuclei.  
( colloidal system formation)  
e.g. sulfur and alcohol in excess of water

### 2) Chemical reaction:

- Hydrogen sulfide  $\xrightarrow{\text{Oxidation}}$  Sulfur atoms  $\longrightarrow$  Sulfur sol.



- Ferric chloride + water  $\xrightarrow{\text{Hydrolysis}}$  Ferric oxide sol. (red color).

- Hydrogen sulfide + arsenous acid  $\xrightarrow{\text{Double decomp}}$  Arsenous sulfide sol.

### 3. Association colloids:

- Certain molecules or ions termed amphiphile (surface active agent SAA) are characterized by two distinct regions of opposing solution affinities within the same molecules or ions.

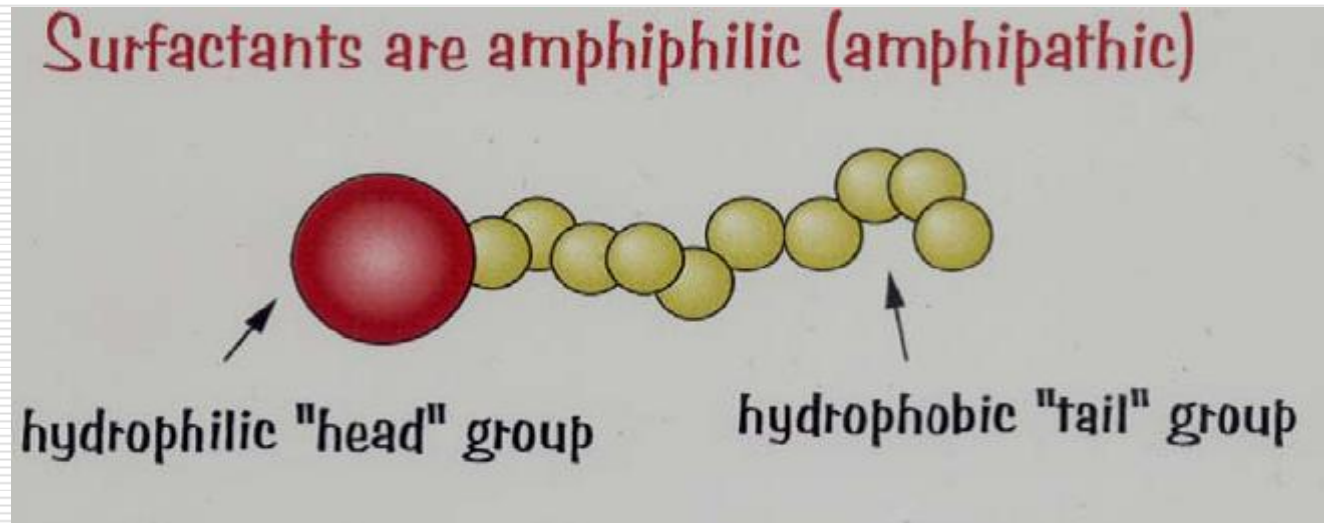

### 3. Association colloids:

- **At low concentration:** amphiphiles exist separately (subcolloidal size)
- **At high concentration:** form aggregates or micelles (50 or more monomers) (colloidal size)

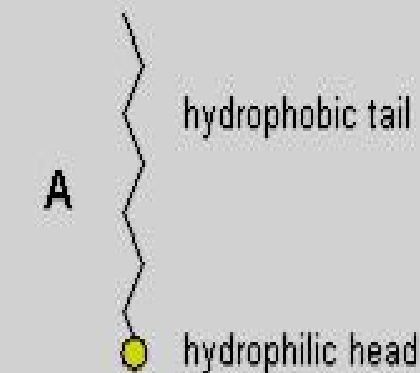

scheme of molecule of surfactant

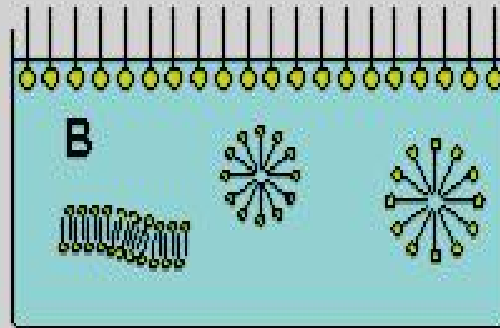

Surfactants arrange themselves on the water surface like a monolayer of molecules, and inside it as micelles and membranes tied by their hydrophobic tail. As the cohesion of these molecules is inferior to that of the molecules of water, the surface tension of water is lowered.

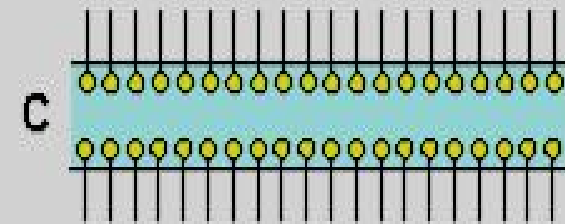

Layer of soapy water. The molecules of surfactant arrange themselves with the head in the water and the tail outside.

### 3. Association colloids:

---

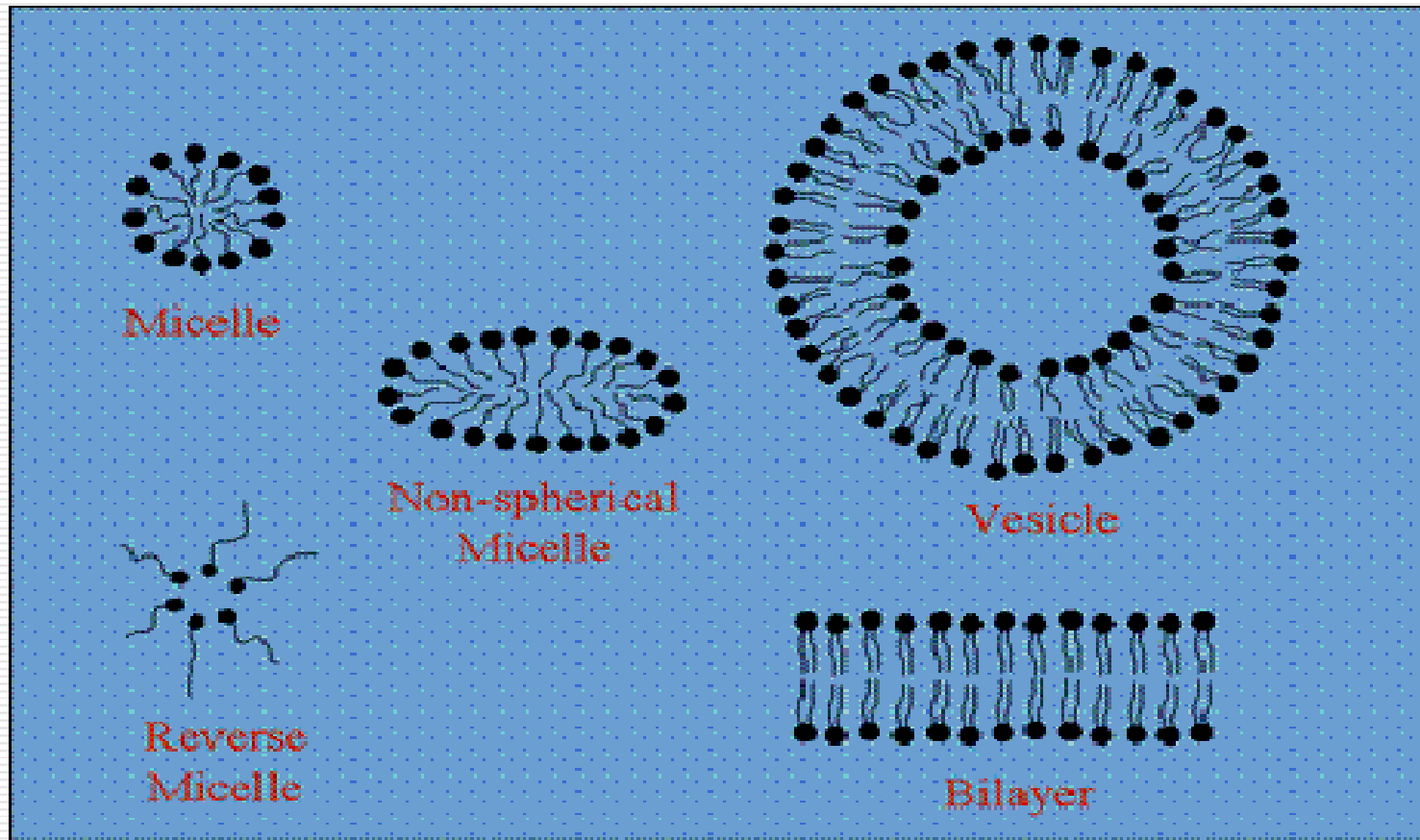

**As with lyophilic sols, formation of association colloids is spontaneous, provided that the concentration of the amphiphile in solution exceeds the cmc.**

---

**Amphiphiles may be**

- 1. Anionic (e.g., Na. lauryl sulfate)**
  - 2. Cationic (e.g., cetyl triethylammonium bromide)**
  - 3. Nonionic (e.g., polyoxyethylene lauryl ether)**
  - 4. Ampholytic (zwitterionic) e.g., dimethyl dodecyl ammonio propane sulfonate.**
-

# Comparison of properties of colloidal sol

	Lyophilic (solvent-loving).	Lyophobic (solvent-hating).	Association (amphophilic).
Dispersed phase	Large organic molecules lying within colloidal size	Inorganic particles such as gold or silver	Aggregates (micelles) of small organic molecules or ions whose size is below the colloidal size
Solvation	Solvated	little	Hydrophilic or lipophilic portion of the molecules is solvated depending on the medium
Preparation	Spontaneous by dissolving in solvent	Needs special procedure	Spontaneous when conc. Of amphiphiles exceeds cmc
Viscosity	Viscosity increased as the conc. increase. At certain conc. Gel sol gel formation.	Not greatly increased due to unsolvation	Increased as conc. Of amphiphile increase as micelles no. increase & become asymmetric.
Effect of electrolytes	Stable in presence of electrolytes Desolvation and salting out in high conc.	Unstable due to neutralization of charges on particles	Cmc is reduced and salting out occur at high salt conc.

## Shape of colloidal particles:

- The more extended the particle, the greater its specific surface & the greater the opportunity for attraction.
- Properties of colloids as Flow, sedimentation rate & O.P. are all affected by the shape of the particles.

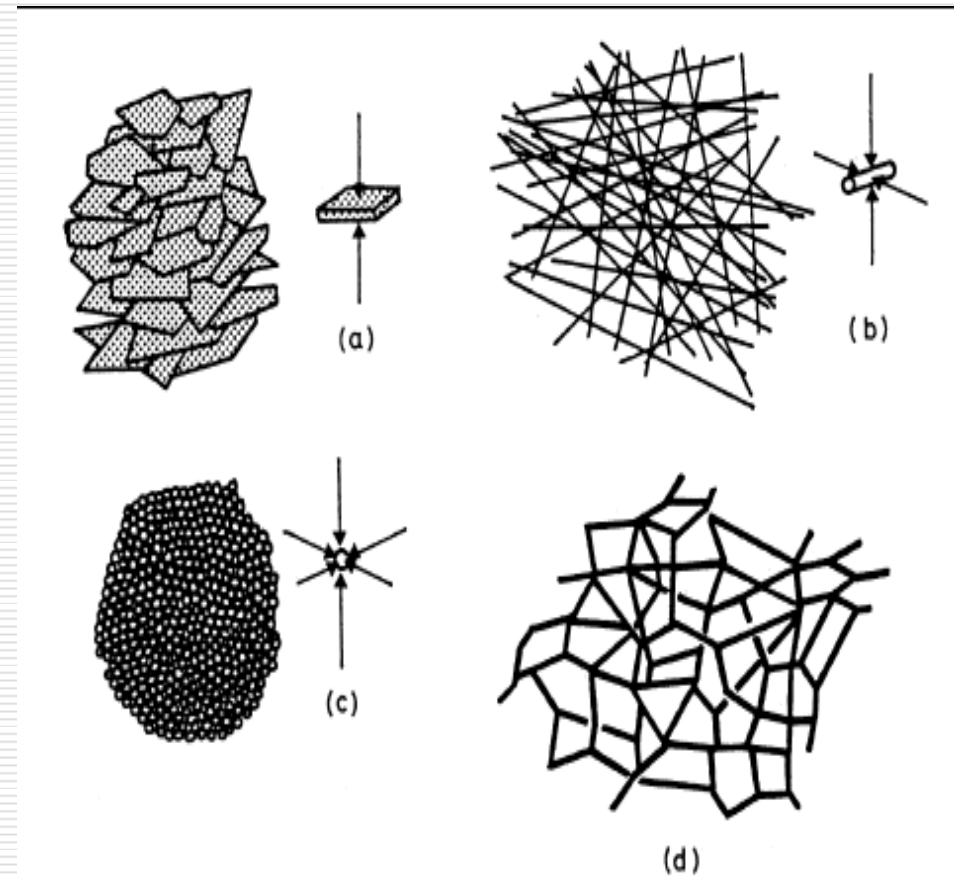

## Purification of colloids

### ○ *1) Why?*

---

**Many lyophobic sols contain more or less material in true solution. which may be undesirable for any number of reasons; e.g.,**

**n electrolyte impurities : cause the flocculation of the sol.**

### • *2) How?*

**a) Dialysis.**

**b) Electro dialysis.**

**c) Ultra filtration.**

---

## a)- Dialysis:

- Depend on difference in size between colloidal particles & molecular particles (impurities).
- Technique;
  - 1) use semi permeable membrane (e.g. collodion (nitrocellulose), cellophane).
  - 2) pore size of used semi permeable membrane prevent passage of colloidal particles & permit passage of small molecules & ions (impurities) **such as urea, glucose, and sodium chloride, to pass through.**
- A type of dialysis equipment; “Neidle dialyzer”
- **At equilibrium, the colloidal material is retained in compartment A, while the subcolloidal material is distributed equally on both sides of the membrane. By continually removing the liquid in compartment B, it is possible to obtain colloidal material in A that is free from subcolloidal contaminants**

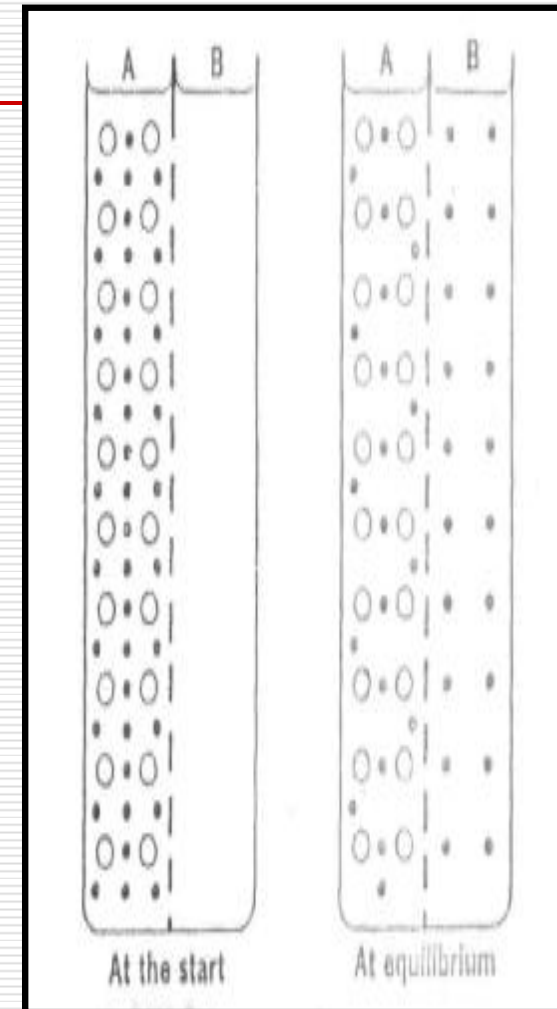

○ **b)- Electro dialysis:**  
Technique;

○ An electric potential may be used to increase the rate of movement of ionic impurities through a dialyzing membrane and so provide rapid purification.

○ Electrodialysis is carried out in a three-compartment vessel with electrodes in the outer compartments containing water and the sol in the center compartment.

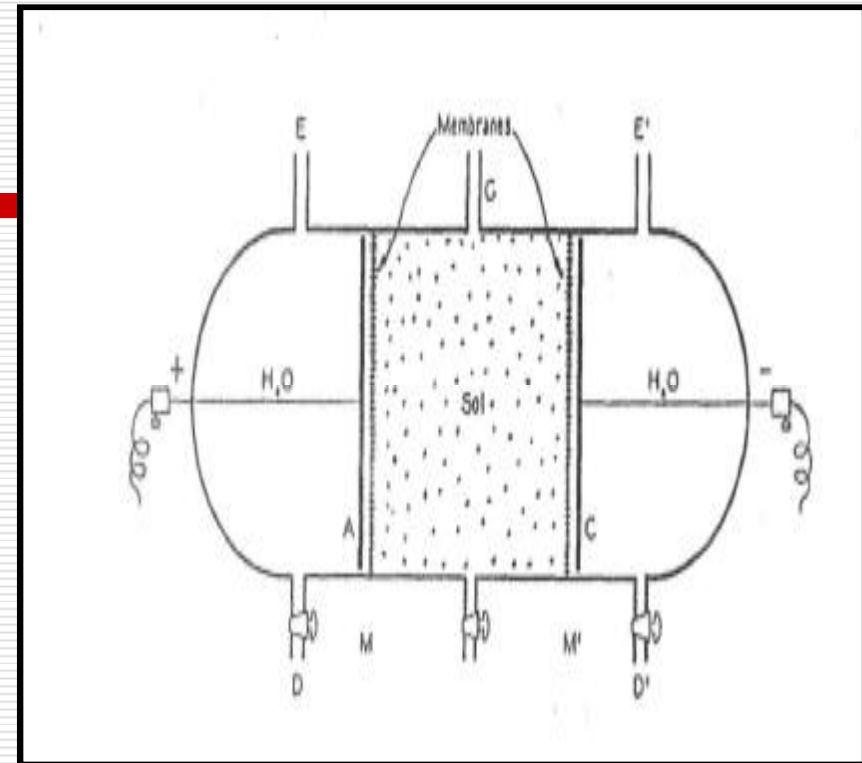

○ A typical apparatus is shown in the figure. Application of electrical potential causes cations to migrate to the negative electrode compartment and anions to move to the positive electrode compartment, in both of which running water ultimately removes the electrolyte.

## c) Ultra filtration:

### • Technique:

**Apply pressure (or suction)** → Solvent & small particles forced across a membrane while colloidal particles are retained.

### *N.B.*

- The membrane must be supported on a sintered glass plate to prevent rupture due to high pressure.
- Pore size of the membrane can be increased by soaking in a solvent that cause swelling
- *e.g. cellophane* swell in zinc chloride solution.

*e.g. collodion* (nitrocellulose) swell in alcohol.

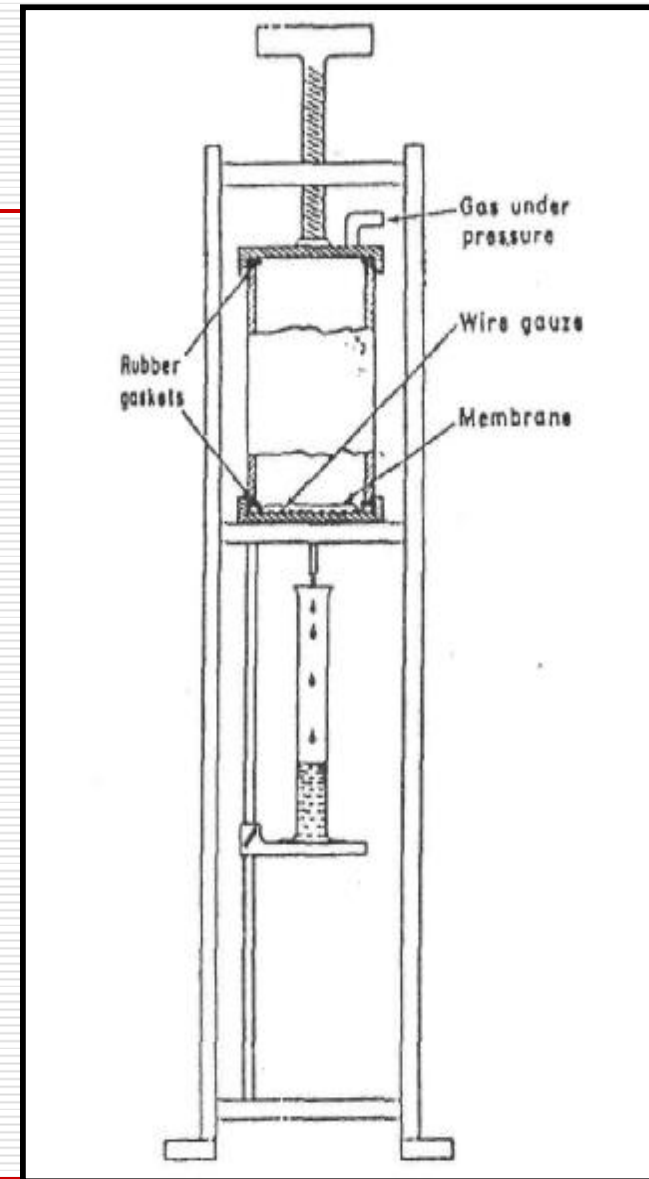

## Artificial kidney machine:

- patient's blood (arterial) pass through  Cellophane coils (ideal semi permeable membrane for haemodialysis).
- cellophane pass urea, glucose, electrolytes but don't pass plasma proteins & blood cells
- pure dialyzed blood enter the body again through a vein.

### N.B.

- *success of the artificial kidney machine depends on its ability to reduce blood urea.*
- *Cellophane coils are supported on a drum rotating in electrolyte solution (rinsing fluid).*

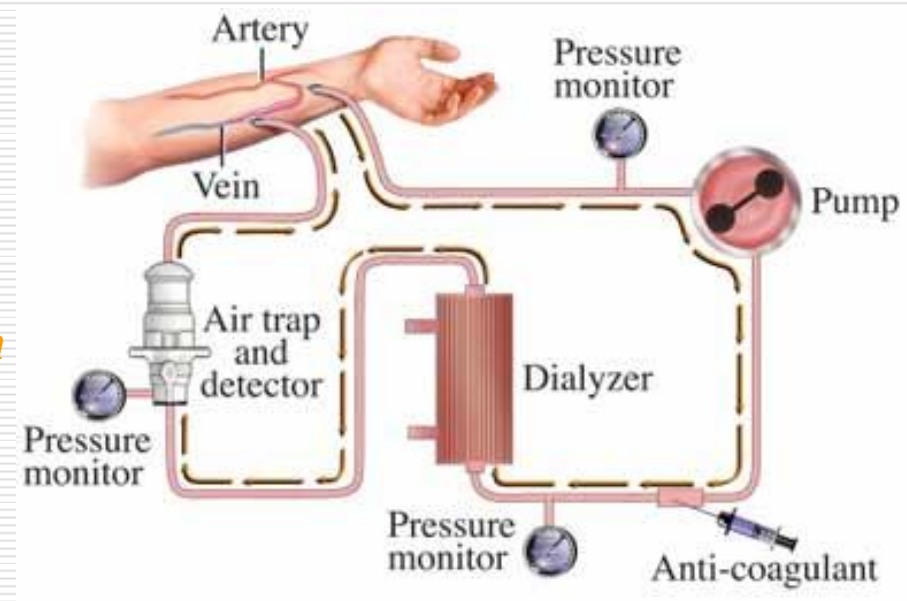

- Suit artificial kidney machine;

---

- Importance of the rinsing solution:

- Substances present in **excess in blood** (e.g. urea) **diffuse** from blood **to the rinsing solution.**

- Substances which are **deficient in blood** (e.g. bicarbonate) **diffuse** from the rinsing solution **to blood.**

- Substances which are present in **normal amounts** in blood are kept **unaltered** have the same conc. In both blood and rinsing solution.

---

## Pharmaceutical applications of colloids;

---

- 1) Colloidal silver iodide, silver chloride & silver protein are effective *germicides* & not cause irritation as ionic silver salts.
  - 2) Colloidal copper used in *cancer*.
  - 3) Colloidal gold used as *diagnostic* agent.
  - 4) Colloidal mercury used in *syphilis*.
  - 5) Association colloids (SAA) are used to *increase solubility & stability* of certain compounds in aqueous & oily pharmaceutical preparations.
-

## Suit Pharmaceutical applications of colloids;

---

6) ***Efficiency*** of certain substances is increased when used in colloidal form due to large surface area.

e.g. efficiency of kaolin in adsorbing toxins from GIT.

e.g. efficiency of aluminum hydroxide as antacid.

7) ***Blood plasma substitutes*** as dextran, PVP & gelatin are hydrophilic colloids used to restore or maintain blood volume.

8) Iron - dextran complex form non-ionic hydrophilic sols used for treatment of ***anemia***.

---

## Properties of colloids

---

- A) Kinetic properties.**
  - B) Optical properties.**
  - C) Electrical properties.**
-

## **A) Kinetic properties:**

---

**Which relate to the motion of the particles within the dispersion medium as following:**

- **Brownian motion.**
  - **Diffusion.**
  - **Sedimentation.**
  - **Osmotic pressure.**
  - **The Donnan membrane effect.**
  - **Viscosity.**
-

# 1) Brownian motion:

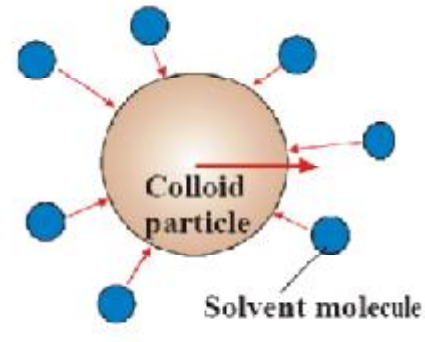

- **Definition:** colloidal particles are subjected to random collision with molecules of the dispersion medium (solvent) so each particle move in irregular and **complicated zigzag pathway**.
- First observed by Robert Brown (1827) with pollen grains suspended in water.
- The velocity of particles **increases** with **decreasing** particle size and viscosity.
- Increasing the viscosity of dispersion medium (**by glycerin**) decrease then stop Brownian motion.

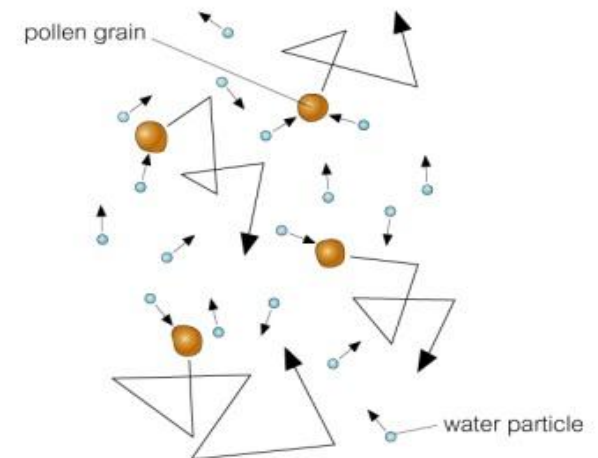
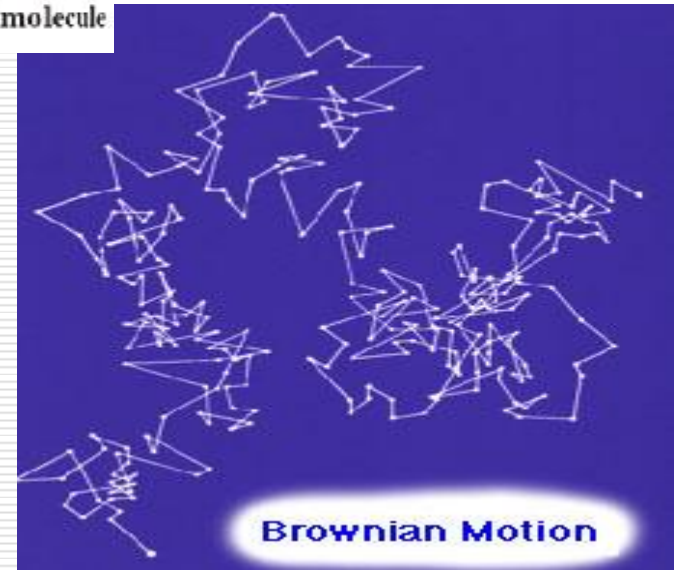

## 2) Diffusion:

- Definition:
- As a result of Brownian motion particles pass (**diffuse**) from a region of **higher** concentration to one with **lower** conc.

- Rate of diffusion is expressed by;  
**Fick's first law:**  
$$dm/dt = -DA dc/dx$$

Where **dm** is the mass of substance diffusing in time **dt** across an area **A** under the influence of a concentration gradient **dC/dx**.

**The minus sign denotes** that diffusion takes place in the direction of decreasing concentration.

**D** is the diffusion coefficient.

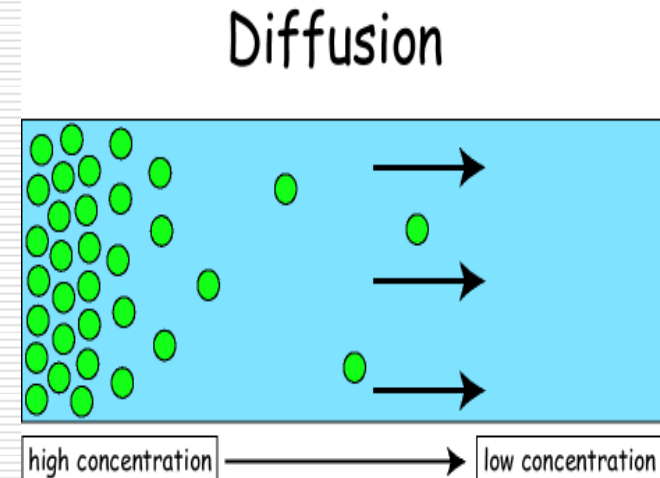

● solute

Solute transport is from the left to the right; movement of the solutes is due to the concentration gradient ( $dC/dx$ ).

### 3) Sedimentation:

#### ○ **Stoke's law;**

---

$$V = \frac{2r^2(\rho - \rho_0)g}{9\eta}$$

- **V**: velocity of sedimentation of spherical particles.
- **$\rho$** : density of the spherical particles.
- **$\rho_0$** : density of the medium.
- **$\eta$** : viscosity of the medium.
- **g**: acceleration due to gravity.

At small particle size (**less than 0.5  $\mu\text{m}$** ) Brownian motion is significant & tend to prevent sedimentation due to gravity & promote mixing in stead.

- 
- so, we use an **ultracentrifuge** which provide stronger force so promote sedimentation in a measurable manner.

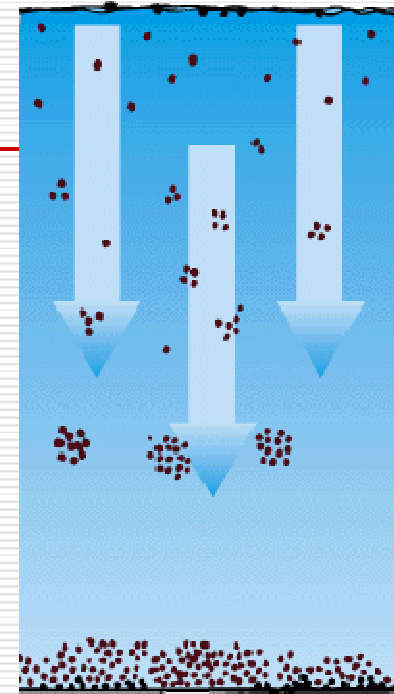

#### 4) Osmotic pressure:

- 
- **The method is based on Van's Hoff's law;**  
$$P = RTC / M$$
  - From the equation;
    - a) **The osmotic pressure (P) depends on molar conc. Of the solute (C) & on absolute temp. (T).**
    - b) **The osmotic pressure is inversely proportional to molecular weight (M).**  
R= molar gas constant
  - **The equation is valid for very dilute solutions in which the molecules do not interact mutually.**
-

## 5) The Donnan membrane effect.

### ○ Definition:

Diffusion of small ions through a membrane will be affected by the presence of a charged macromolecule that can't penetrate the membrane due to its size.

### Application:

- 1) Facilitating the absorption of ionizable drugs from GIT by co-administration of macromolecules of same charge so mutual ionic repulsion occurs e.g

co-administration of anionic macromolecule e.g. sodium carboxy methyl cellulose, with a diffusible anion e.g. potassium benzyl penicillin to enhance diffusion of the later across body membranes.

### Donnan Membrane Equilibrium

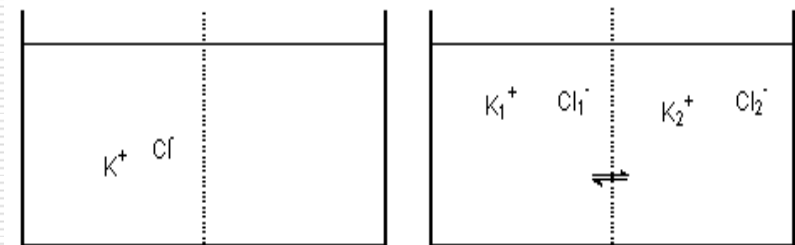

$$\text{Rate of diffusion} = k[K^+][Cl^-]$$

At equilibrium

$$[K_1^+][Cl_1^-] = [K_2^+][Cl_2^-]$$

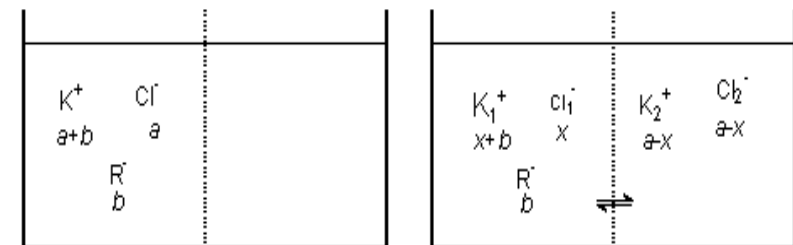

At equilibrium

$$x = \frac{a^2}{2a + b}$$

## 6) viscosity

---



### ○ Definition:

- The resistance to flow of a system under an applied pressure
- **Viscosity of colloid allows** 1- calculation of the molecular weight.  
2- Provide useful information about the shape of the colloidal particles.

### ○ N.B.

- **Spherocolloidal** dispersions are of relatively **low viscosity**.
- **On the other hand Linear colloidal** dispersions are of **high viscosity**.
- **If linear colloidal particles coil up into spheres**

---

The **viscosity** of the system **falls due to changing the shape**.

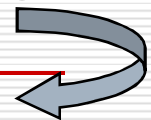

## **B) Optical properties:**

---

**1) Light scattering (Tyndall effect).**

**1) Ultra microscope.**

**2) Electron microscope.**

---

## 1) Light scattering (Tyndall effect)

- True solutions do not scatter light and appear clear but colloidal dispersions contain opaque particles that do scatter light and thus appear turbid.
- Tyndall effect:  
when a beam of light pass through a colloidal sol, scattered light cause the sol to *appear turbid*.
  
- Importance of light scattering measurements:
  - 1) Estimate particle size.
  - 2) Estimate particle shape.
  - 3) Estimate particles interactions.

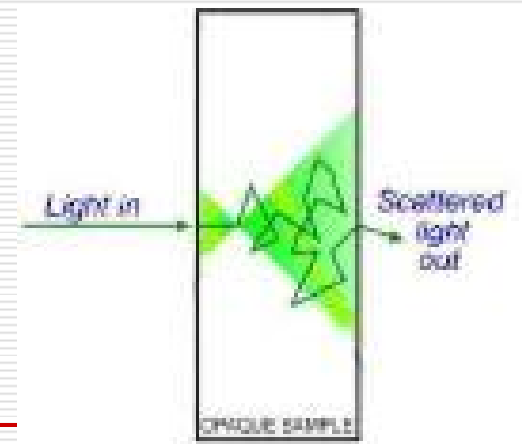

---

# The Faraday-Tyndall effect



Tyndal Effect: Laser Pointer traveling through a solution (right) and through a colloidal suspension (left).

## 2) Ultra microscope



- Particles appear as spots of light against the dark background of the microscope.
- Used in the technique of micro electrophoresis for measuring particle charge.

## 3) Electron microscope:



- Give actual picture of the particles (up to 5Å).
- Used to observe the size, shape and structure of sols.
- High energy electron beams are used. (have greater resolving power)
- **One disadvantage is;** only dried samples can be examined. Not give information on solvation.

## **C) Electrical properties:**

---

**a) Electrical properties of interfaces.**

**b) The electrical double layer.**

---

## **a) Electrical properties of interfaces:**

---

**Most surfaces acquire a surface electric charge when brought into contact with an aqueous medium, the principal charging mechanisms being as follows:**

**1) Ion dissolution.**

**2) Ionization.**

**3) Ion adsorption.**

---

## 1) Ion dissolution:

---

- Surface charge of colloidal particle **is controlled by** the charge of ion present in excess in the medium.
- Examples: 1)  $\text{AgNO}_3 + \text{NaI} \Rightarrow \text{AgI} + \text{NaNO}_3$ 
  - a) silver iodide in a solution with **excess iodide**  $\Rightarrow$  Particles **acquire - ve** charge & vice versa. if excess Ag the charge will be +ve **since the conc. Of Ag and I determine the electric potential**
  - b) Aluminum hydroxide in a solution with **excess hydroxide**  $\Rightarrow$  particles acquire – ve charge & vice versa.

Potential determining ions: ions whose conc. determine the electric potential at the particle surface (e.g.  $\text{Ag}^+$ ,  $\text{I}^-$ ,  $\text{H}^+$ ,  $\text{OH}^-$ )

---

## 2) Ionization

- Surface charge of colloidal particle **is controlled by the ionization of surface groupings**
- Examples:
  - a) polystyrene latex has carboxylic acid group at the surface, ionize to give negatively charged particles.
  - b) acidic drugs as ibuprofen & nalidixic acid acquire surface negative charged.
  - c) Amino acids & proteins have carboxyl & amino groups whose ionization depend on the pH as follow;

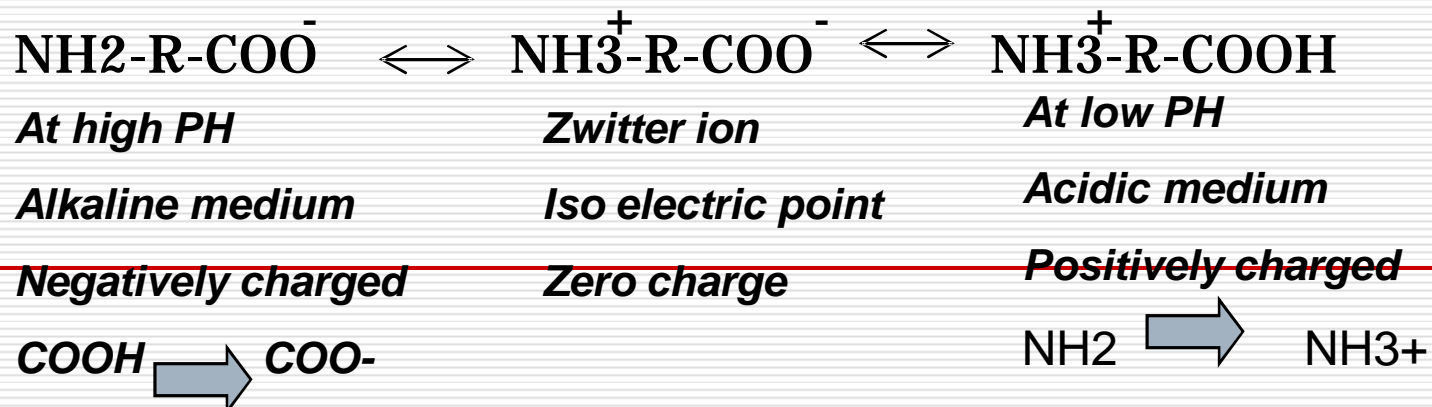

## Suit ionization;

---

- Iso electric point:
  - **pH** at which **+ve** charges = **-ve** charges,
  - i.e. **net charge** of the amino acid = **zero**.
  - It is a definite pH **specific** for each protein.
  - At this pH protein is **least soluble** & precipitated.
  
  - **Q; How can you precipitate insulin???**
  
  - **BY ADJUSTING THE *pH* OF the SOLUTION TO THE ISO ELECTRIC POINT OF INSULIN (PH 5.2).**
-

### 3) Ion adsorption:

---

- Surface charge of colloidal particle **is controlled by** the unequal adsorption of oppositely charged ions
- Examples:
- Surfaces of sol in water are more often –ve charged than +ve charged ?!!!

Because **cations are more hydrated than anions** so cations reside in the bulk while less hydrated anions adsorbed on the surface.

---

## b) The electrical double layer:

- Definition:

- Development of a net charge at the particle surface affects the distribution of ions in the surrounding interfacial region,
- As a result: concentration of counter ions increase at the surface,
- Thus, an electrical double layer exists around each particle.

- Example:

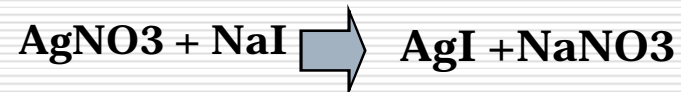

• At xs NaI :

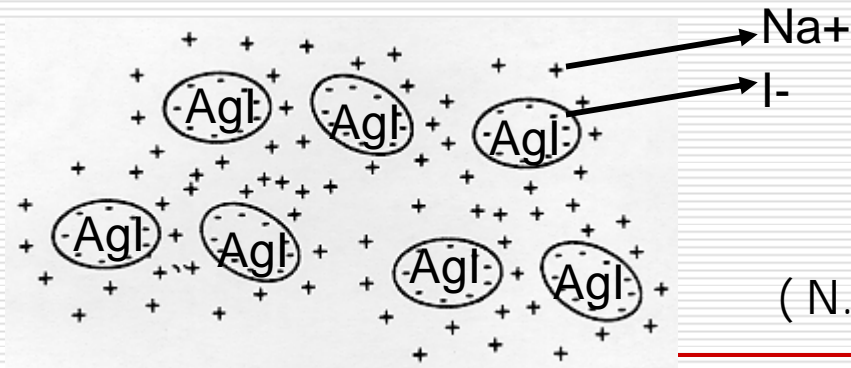

( N.B. Vice versa if xs AgNO<sub>3</sub> )

- Silver iodide sols can be prepared by the reaction,



- In the **bulk of AgI** particles  $\Rightarrow$  1 : 1 ratio of  $\text{Ag}^+$  and  $\text{I}^-$
- 

- If the reaction is carried out with an **excess silver nitrate**, there will be more  $\text{Ag}^+$  than  $\text{I}^-$  ions in the surface of the particles  $\Rightarrow$  The particles will thus be **positively charged** and the **counterions** surrounding them will be  $\text{NO}_3^-$ .

- The combination of the **positively charged** surface and the atmosphere of **counter ions** surrounding it is called **the electric double layer**.

- If the reaction is carried out with an **excess NaI**, there will be more  $\text{I}^-$  than  $\text{Ag}^+$  ions in the surface of the particles  $\Rightarrow$  The particles will thus be **negatively charged** and the counter ions surrounding them will be  $\text{Na}^+$ .
-